

**NORME
INTERNATIONALE**

**CEI
IEC**

**INTERNATIONAL
STANDARD**

60068-2-75

Première édition
First edition
1997-08

Essais d'environnement –

Partie 2:

Essais – Essai Eh: Essais aux marteaux

Environmental testing –

Part 2:

Tests – Test Eh: Hammer tests

© IEC 1997 Droits de reproduction réservés — Copyright - all rights reserved

Aucune partie de cette publication ne peut être reproduite ni utilisée sous quelque forme que ce soit et par aucun procédé, électronique ou mécanique, y compris la photocopie et les microfilms, sans l'accord écrit de l'éditeur.

No part of this publication may be reproduced or utilized in any form or by any means, electronic or mechanical, including photocopying and microfilm, without permission in writing from the publisher.

International Electrotechnical Commission
Telefax: +41 22 919 0300

3, rue de Varembé Geneva, Switzerland
IEC web site <http://www.iec.ch>



Commission Electrotechnique Internationale
International Electrotechnical Commission
Международная Электротехническая Комиссия

CODE PRIX
PRICE CODE

V

*Pour prix, voir catalogue en vigueur
For price, see current catalogue*

CONTENTS

	Page
FOREWORD	7
INTRODUCTION	9
Clause	
1 Scope	11
2 Normative references	11
3 Provisions: common to all hammer test methods	13
3.1 Definitions	13
3.2 Severities	13
3.2.1 General	13
3.2.2 Impact energy value	13
3.2.3 Number of impacts	13
3.3 Test apparatus	13
3.3.1 Description	13
3.3.2 Mounting	15
3.4 Preconditioning	17
3.5 Initial measurements	17
3.6 Testing	17
3.6.1 Attitudes and impact locations	17
3.6.2 Preparation of the specimen	17
3.6.3 Operating mode and functional monitoring	17
3.7 Recovery	17
3.8 Final measurements	19
3.9 Information to be given in the relevant specification	19
4 Test Eha: Pendulum hammer	21
4.1 Definitions	21
4.2 Test apparatus	21
4.2.1 Test apparatus for severities not exceeding 1 J	21
4.2.2 Test apparatus for severities of 2 J and above	21
4.3 Height of fall	23
4.4 Testing	23
5 Test Ehb: Spring hammer	25
5.1 Test apparatus	25
5.2 Influence of earth's gravity	27
5.3 Calibration	27
6 Test Ehc: Vertical hammer	29
6.1 Definition	29
6.2 Test apparatus	29
6.3 Height of fall	29

Figures

1	Example sketch of the striking element.....	15
2	Derivation of measuring point.....	23
3	Shape of release head for 2 J.....	25
A.1	Example of a striking element for ≤ 1 J.....	31
A.2	Example of a striking element for 2 J.....	31
A.3	Example of a striking element for 5 J.....	33
A.4	Example of a striking element for 10 J.....	33
A.5	Example of a striking element for 20 J.....	35
A.6	Example of a striking element for 50 J.....	35
B.1	Calibration device.....	41
B.2	Pendulum "c".....	43
B.3	Steel spring of pendulum "c".....	45
B.4	Details of calibration device.....	47
B.5	Arrangement for the calibration of the calibration device.....	49
B.6	Division of scale plate "f".....	51
D.1	Test apparatus.....	59
D.2	Striking element of the pendulum hammer for energies ≤ 1 J.....	59
D.3	Mounting fixture.....	61
D.4	Adapter for flush-type switches.....	61
D.5	Adapter for lamp holders.....	63
E.1	Spring hammer test apparatus.....	67

Annexes

A	Shapes of striking elements.....	31
B	Procedure for the calibration of spring hammers.....	37
C	Guidance.....	53
D	Example of pendulum hammer test apparatus.....	57
E	Example of spring hammer test apparatus.....	65

COMMISSION ÉLECTROTECHNIQUE INTERNATIONALE

**ESSAIS D'ENVIRONNEMENT –
Partie 2: Essais –
Essai Eh: Essais aux marteaux**

AVANT-PROPOS

- 1) La CEI (Commission Electrotechnique Internationale) est une organisation mondiale de normalisation composée de l'ensemble des comités électrotechniques nationaux (Comités nationaux de la CEI). La CEI a pour objet de favoriser la coopération internationale pour toutes les questions de normalisation dans les domaines de l'électricité et de l'électronique. A cet effet, la CEI, entre autres activités, publie des Normes internationales. Leur élaboration est confiée à des comités d'études, aux travaux desquels tout Comité national intéressé par le sujet traité peut participer. Les organisations Internationales, gouvernementales et non gouvernementales, en liaison avec la CEI, participent également aux travaux. La CEI collabore étroitement avec l'Organisation Internationale de Normalisation (ISO), selon des conditions fixées par accord entre les deux organisations.
- 2) Les décisions ou accords officiels de la CEI concernant les questions techniques représentent, dans la mesure du possible un accord international sur les sujets étudiés, étant donné que les Comités nationaux intéressés sont représentés dans chaque comité d'études.
- 3) Les documents produits se présentent sous la forme de recommandations internationales. Ils sont publiés comme normes, rapports techniques ou guides et agréés comme tels par les Comités nationaux.
- 4) Dans le but d'encourager l'unification internationale, les Comités nationaux de la CEI s'engagent à appliquer de façon transparente, dans toute la mesure possible, les Normes internationales de la CEI dans leurs normes nationales et régionales. Toute divergence entre la norme de la CEI et la norme nationale ou régionale correspondante doit être indiquée en termes clairs dans cette dernière.
- 5) La CEI n'a fixé aucune procédure concernant le marquage comme indication d'approbation et sa responsabilité n'est pas engagée quand un matériel est déclaré conforme à l'une de ses normes.
- 6) L'attention est attirée sur le fait que certains des éléments de la présente Norme internationale peuvent faire l'objet de droits de propriété intellectuelle ou de droits analogues. La CEI ne saurait être tenue pour responsable de ne pas avoir identifié de tels droits de propriété et de ne pas avoir signalé leur existence.

La Norme internationale CEI 60068-2-75 a été établie par le comité d'études 104 de la CEI: Conditions, classification et essais d'environnement.*

Cette première édition de la CEI 60068-2-75 annule et remplace la CEI 60068-2-62 parue en 1991 et l'amendement 1 (1993) ainsi que la CEI 60068-2-63, parue en 1991, et constitue une révision technique.

Elle a le statut d'une publication fondamentale de sécurité conformément au Guide CEI 104.

Elle a le statut d'une publication fondamentale d'essais d'environnement conformément au Guide CEI 108.

Le texte de cette norme est issu des documents suivants:

FDIS	Rapport de vote
50A/328/FDIS	104/39/RVD

Le rapport de vote indiqué dans le tableau ci-dessus donne toute information sur le vote ayant abouti à l'approbation de cette norme.

Les annexes A et B font partie intégrante de cette norme.

Les annexes C, D, et E sont données uniquement à titre d'information.

* Précédemment CE 50 et ses sous-comités SC 50A et 50B.

INTERNATIONAL ELECTROTECHNICAL COMMISSION

**ENVIRONMENTAL TESTING –
Part 2: Tests –
Test Eh: Hammer tests**

FOREWORD

- 1) The IEC (International Electrotechnical Commission) is a worldwide organization for standardization comprising all national electrotechnical committees (IEC National Committees). The object of the IEC is to promote international co-operation on all questions concerning standardization in the electrical and electronic fields. To this end and in addition to other activities, the IEC publishes International Standards. Their preparation is entrusted to technical committees; any IEC National Committee interested in the subject dealt with may participate in this preparatory work. International, governmental and non-governmental organizations liaising with the IEC also participate in this preparation. The IEC collaborates closely with the International Organization for Standardization (ISO) in accordance with conditions determined by agreement between the two organizations.
- 2) The formal decisions or agreements of the IEC on technical matters express, as nearly as possible, an international consensus of opinion on the relevant subjects since each technical committee has representation from all interested National Committees.
- 3) The documents produced have the form of recommendations for international use and are published in the form of standards, technical reports or guides and they are accepted by the National Committees in that sense.
- 4) In order to promote international unification, IEC National Committees undertake to apply IEC International Standards transparently to the maximum extent possible in their national and regional standards. Any divergence between the IEC Standard and the corresponding national or regional standard shall be clearly indicated in the latter.
- 5) The IEC provides no marking procedure to indicate its approval and cannot be rendered responsible for any equipment declared to be in conformity with one of its standards.
- 6) Attention is drawn to the possibility that some of the elements of this International Standard may be the subject of patent rights. The IEC shall not be held responsible for identifying any or all such patent rights.

International Standard CEI 60068-2-75 has been prepared by IEC technical committee 104: Environmental conditions, classification and methods of test.*

This first edition of CEI 60068-2-75 replaces both IEC 60068-2-62, published in 1991 including amendment 1 (1993) and IEC 60068-2-63, published in 1991, and constitutes a technical revision.

It has the status of a basic safety publication in accordance with IEC Guide 104.

It has the status of a basic environmental testing publication in accordance with IEC Guide 108.

The text of this standard is based on the following documents:

FDIS	Report on voting
50A/328/FDIS	104/39/RVD

Full information on the voting for the approval of this standard can be found in the report on voting indicated in the above table.

Annexes A and B form an integral part of this standard.

Annexes C, D and E are for information only.

* Formerly TC 50 and SCs 50A and 50B.

INTRODUCTION

Mechanical impacts likely to stress electrotechnical equipment in service can be generated by hammers of various types. For standardization purposes, the results of such testing should not depend on the type of testing apparatus and therefore, the characteristics of the various types of test hammers described in this part of IEC 60068 are intended to be as close as practicable for the same severity level.

It is important to note that both clause 3 and the test method selected from clauses 4, 5, and 6 need to be complied with in order to satisfy the requirements of this International Standard.

The severity levels are, in general, taken from IEC 60721-1.

For co-ordination purposes, it has been necessary to change certain fundamental parameters of the previous tests Ef: Impact, pendulum hammer, and Eg: Impact, spring hammer. In all cases, both sets of parameters are shown at the appropriate places in the text and will remain valid until five years from the publication of this part of IEC 60068. At that time, the values in brackets will be removed.

ENVIRONMENTAL TESTING –
Part 2: Tests –
Test Eh: Hammer tests

1 Scope

This part of IEC 60068 provides three standardized and co-ordinated test methods for determining the ability of a specimen to withstand specified severities of impact. It is used, in particular, to demonstrate an acceptable level of robustness when assessing the safety of a product and is primarily intended for the testing of electrotechnical items. It consists of the application to the specimen of a prescribed number of impacts defined by their impact energy and applied in the prescribed directions.

This part of IEC 60068 covers energy levels ranging from 0,14 joules (J) to 50 joules (J).

Three types of test apparatus are applicable to perform these tests. Annex C provides some guidance as to this aspect.

2 Normative references

The following normative documents contain provisions which, through reference in this text, constitute provisions of this part of IEC 60068. At the time of publication, the editions indicated were valid. All normative documents are subject to revision, and parties to agreements based on this part of IEC 60068 should investigate the possibility of applying the most recent editions of the standards listed below. Members of IEC and ISO maintain registers of currently valid International Standards.

IEC 60068-1: 1988, *Environmental testing – Part 1: General and guidance*

IEC 60721-1: 1990, *Classification of environmental conditions – Part 1: Environmental parameters and their severities*
Amendment 1, 1992

ISO 1052: 1982, *Steels for general engineering purposes*

ISO 2039-2: 1987, *Plastics – Determination of hardness – Part 2: Rockwell hardness*

ISO 2041: 1990, *Vibration and shock – Vocabulary*

ISO 2768-1: 1989, *General tolerances – Part 1: Tolerances for linear and angular dimensions without individual tolerances indicated*

ISO 6508: 1986, *Metallic materials – Hardness test – Rockwell test (scales A – B – C – D – E – F – G – H – K)*

3 Provisions common to all hammer test methods

3.1 Definitions

For the purpose of this part of IEC 60068, the terms used are generally defined in ISO 2041 or in IEC 60068-1. The following additional common definitions are also applicable for the purpose of this part of IEC 60068. Definitions specific to the tests of clauses 4 and 6 are given therein.

3.1.1 fixing point: Part of the specimen in contact with the mounting fixture at the point where the specimen is normally fastened in service.

3.1.2 equivalent mass: Mass of the striking element and any relevant portions of the test apparatus which, combined with its velocity, provides the impact energy.

NOTE – For the particular application to the pendulum hammer apparatus, see 4.1.3.

3.2 Severities

3.2.1 General

The severity is defined by the impact energy value chosen from 3.2.2, and the number of impacts according to 3.2.3.

3.2.2 Impact energy value

The impact energy value shall be one of the following, as prescribed by the relevant specification:

0,14 – 0,2 – (0,3) – 0,35 – (0,4) – 0,5 – 0,7 – 1 – 2 – 5 – 10 – 20 – 50 joules.

NOTE – Figures in brackets appear in current IEC 60068-2 standards, but will be removed five years from the date of publication of this standard.

3.2.3 Number of impacts

Unless otherwise prescribed by the relevant specification, the number of impacts shall be three per location.

3.3 Test apparatus

3.3.1 Description

Three types of test apparatus are available to perform these tests:

- the pendulum hammer;
- the spring hammer;
- the vertical hammer.

The types of test apparatus are defined in clauses 4, 5 and 6 as tests Eha, Ehb and Ehc respectively. The co-ordinated characteristics of the striking element are, in principle, similar in all three cases and are stated in table 1, in relation to the outline shown in figure 1.

Dimensions are in millimetres. Tolerances are as per class m of ISO 2768-1, unless otherwise stated.

Table 1 – Co-ordinated characteristics of the striking elements

Energy value J	≤1 ±10 %	2 ±5 %	5 ±5 %	10 ±5 %	20 ±5 %	50 ±5 %
Equivalent mass ±2% kg	0,25 (0,2)	0,5	1,7	5	5	10
Material	Polyamide ¹⁾	Steel ²⁾				
R mm	10	25	25	50	50	50
D mm	18,5 (20)	35	60	80	100	125
f mm	6,2(10)	7	10	20	20	25
r mm	–	–	6	–	10	17
l mm	To be adjusted to match the equivalent mass, see annex A.					
¹⁾ 85≤HRR≤100, Rockwell hardness according to ISO 2039-2. ²⁾ Fe 490-2, according to ISO 1052: Rockwell hardness: HRE 80...85 according to ISO 6508. NOTE – The values shown in brackets for the equivalent mass and the diameter of the striking element for the energy value equal to or less than 1 J are those in the current test Ef. The values currently in test Eg are also shown for these two parameters. For co-ordination purposes, the values in brackets will be deleted five years from the publication of this standard.						

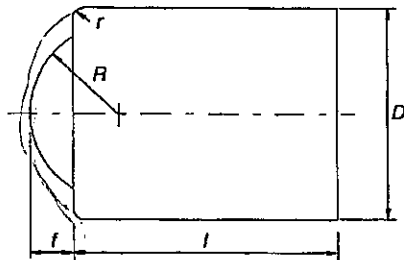

IEC 958/97

Figure 1 – Example sketch of a striking element

The striking surface shall be visually examined before each impact in order to ensure that there is no damage that might affect the result of the test.

3.3.2 Mounting

As prescribed by the relevant specification, the specimen shall either:

- a) be mounted by its normal means on a rigid plane support, or
- b) be placed against a rigid plane support.

In order to ensure that the specimen is rigidly supported, it may be necessary when performing the test to place the specimen against a plane solid support, for example a wall or a floor made of brick or concrete, covered by a sheet of polyamide which is tightly fixed to the support.

Care shall be taken to ensure that there is no appreciable air gap between the sheet and the support. The sheet shall have a Rockwell hardness of $85 \leq \text{HRR} \leq 100$ according to ISO 2039-2, a thickness of approximately 8 mm and a surface area such that no parts of the specimen are mechanically over stressed due to the supporting area being insufficient.

The mounting arrangement is deemed to be sufficiently rigid if the displacement of the impact surface of the plane support does not exceed 0,1 mm when struck by an impact applied directly to it with the same level of energy as for the specimen.

NOTES

- 1 For specimens to be subjected to impact energies not exceeding 1 J, some examples of mounting and support are shown in figures D.3, D.4 and D.5.
- 2 When the mass of the mounting is at least 20 times that of the specimen, the rigidity of the mounting is likely to be sufficient.

3.4 *Preconditioning*

The relevant specification may call for preconditioning and shall then prescribe the conditions.

3.5 *Initial measurements*

The specimen shall be submitted to the visual, dimensional and functional checks prescribed by the relevant specification.

3.6 *Testing*

Secondary impacts, i.e. rebounds, shall be avoided.

3.6.1 *Attitudes and impact locations*

The relevant specification shall prescribe the attitudes of the specimen and the locations on the specimen, corresponding to where damage is most likely to occur in practice, and at which the impacts are to be applied. Unless otherwise specified by the relevant specification, the blows shall be applied perpendicularly to the tested surface.

3.6.2 *Preparation of the specimen*

The relevant specification shall state any requirements for the securing of bases, covers, and similar items before the specimen is subjected to the impacts.

NOTE – Account may need to be taken of requirements for functional monitoring (see 3.6.3b).

3.6.3 *Operating mode and functional monitoring*

The relevant specification shall state:

- a) whether the specimen is required to operate during impact;
- b) whether any functional monitoring is required.

In both cases the relevant specification shall provide the criteria upon which the acceptance or rejection of the specimen is to be based.

NOTE – Attention is drawn to the fact that, in case of breakage of the specimen, internal parts may become hazardous.

3.7 *Recovery*

The relevant specification may call for recovery and shall then prescribe the conditions.

3.8 Final measurements

The specimen shall be submitted to the visual, dimensional and functional checks prescribed by the relevant specification.

The relevant specification shall prescribe the criteria upon which the acceptance or rejection of the specimen is to be based.

3.9 Information to be given in the relevant specification

When one of the tests in this part of IEC 60068 is included in a relevant specification, the following details shall be given as far as they are applicable, paying particular attention to the items marked with an asterisk (*) as this information is always required:

	<i>Subclause</i>
a) Impact energy *	3.2.2
b) Number of impacts, if other than three per location	3.2.3
c) Type(s) of test apparatus to be used	3.3.1
d) Method of mounting *	3.3.2
e) Preconditioning	3.4
f) Initial measurements*	3.5
g) Attitude and impact locations *	3.6.1
h) Securing of bases, covers and similar components	3.6.2
i) Operating mode and functional monitoring*	3.6.3
j) Acceptance and rejection criteria *	3.6.3 and 3.8
k) Conditions for recovery	3.7
l) Final measurements*	3.8

4 Test Eha: Pendulum hammer

4.1 Definitions

The following additional terms and definitions are applicable for the purpose of this test method.

4.1.1 measuring point: Point marked on the surface of the striking element where the line through the point of intersection of the axes of the arms of both of the pendulum and of the striking element, and perpendicular to the plane through both axes, meets the surface (see figure 2).

NOTES

- 1 In some IEC standards which include a pendulum hammer test, the term "checking point" has been used but it has not been used here in order to avoid confusion with "check point" in other parts of IEC 60068-2.
- 2 Theoretically, the centre of gravity of the striking element should be the measuring point. In practice, the centre of gravity is either difficult to determine or inaccessible, and the measuring point is therefore defined as above.

4.1.2 height of fall: Vertical distance between the position of the measuring point when the pendulum is released and its position at the moment of impact (see figure D.1).

4.1.3 equivalent mass: The mass of the simple pendulum hammer calculated from the measure of the vertical force (in newtons) to be applied in the axis of the striking element to maintain the arm of the pendulum in a horizontal position, divided by the earth's gravity.

NOTE – When the mass of the arm is evenly distributed, the equivalent mass is equal to the sum of the combined mass of the striking element plus half the mass of the arm.

4.1.4 combined mass of the striking element: The sum of the masses of the striking element and of the element's fixing system.

4.2 Test apparatus

The test apparatus consists basically of a pendulum rotating at its upper end in such a way as to be kept in a vertical plane. The axis of the pivot is at 1000 mm above the measuring point. The pendulum is composed of a nominally rigid arm and of a striking element complying with the requirements of table 1.

For testing heavy, voluminous or difficult to handle specimens, a portable pendulum may be used. It shall comply with the above description but its pivot may be fixed directly on the specimen or on a movable structure. In this case, it shall be ensured that, before the tests, the axis of the pendulum is horizontal, that its fixing is sufficiently rigid, and that the impact point is in the vertical plane passing through the axis.

In all cases, when the pendulum is released, it shall be allowed to fall only under the influence of gravitational force.

4.2.1 Test apparatus for severities not exceeding 1 J

The striking element comprises a steel body with a polyamide insert having a hemispherical face. Its combined mass is 200 g (150 g) \pm 1 g so that the equivalent mass complies with table 1. Annex D gives an example of a test apparatus.

4.2.2 Test apparatus for severities of 2 J and above

The ratio of the mass of the arm to the combined mass of the striking element shall not be greater than 0,2 and the centre of gravity of the striking element shall be as close as is practicable to the axis of the arm.

NOTE – For some particular applications the pendulum arm is replaced by a cord and the striking element by a spherical steel ball. This is not recommended as the ball does not conform to the geometry of the striking element specified in this part of IEC 60068.

4.3 Height of fall

To produce impacts of the required severity, the striking element shall be released from a height depending on the equivalent mass of the pendulum, according to table 2.

Table 2 – Height of fall

Energy J	0,14	0,2		(0,3)	0,35	(0,4)	0,5		0,7	1	2	5	10	20	50
Equivalent mass kg	0,25	(0,2)	0,25	(0,2)	0,25	(0,2)	(0,2)	0,25	0,25	0,25	0,5	1,7	5	5	10
Height of fall mm ± 1 %	56	(100)	80	(150)	140	(200)	(250)	200	280	400	400	300	200	400	500

NOTES

1 See note in 3.2.2.

2 In this part of IEC 60068, the energy, J, is calculated taking the standard acceleration due to the earth's gravity (g_n), rounded up to the nearest whole number, that is 10 m/s².

4.4 Testing

In order to avoid secondary impacts, i.e. rebounds, the hammer shall be retained after the initial impact by grasping the striking element whilst avoiding the arm so that distortion is prevented.

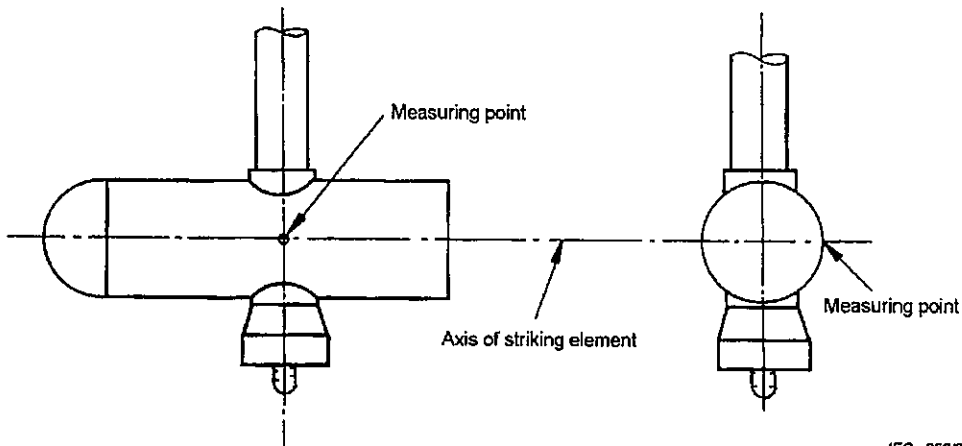

IEC 959/97

Figure 2 – Derivation of measuring point

5 Test Ehb: Spring hammer

5.1 Test apparatus

The spring hammer consists of three principal parts: the body, the striking element and the release system.

The body comprises the housing, the guide for the striking element, the release mechanism and all parts rigidly fixed thereto.

The striking element comprises the hammer head, the hammer shaft and the cocking knob. The mass of this assembly is 250 g for severities not exceeding 1 J, and 500 g for 2 J (see table 1 for tolerances).

The pressure to release the striking element shall not exceed 10 N.

The configuration of the hammer shaft, the hammer head and the means for the adjustment of the hammer spring is such that the hammer spring has released all its stored energy approximately 1 mm before the tip of the hammer head reaches the plane of impact. For the last millimetre of its travel, prior to impact, the striking element is thus, apart from friction, a freely moving mass having only kinetic energy and no stored energy. Moreover, after the tip of the hammer head has passed the plane of impact, the striking element is free to travel, without interference, over a further distance of between 8 mm and 12 mm. Annex E gives an example of a test apparatus.

In order to comply with table 1, the shape of the release head for 2 J shall be cylindrical for a length of 23 mm with a diameter of 35 mm (see figure 3).

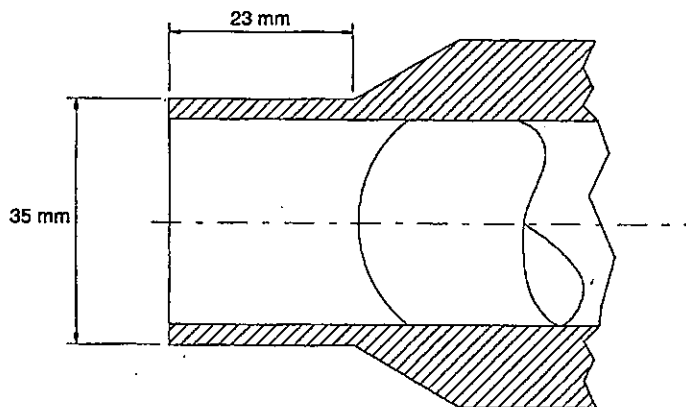

IEC 960/97

Figure 3 – Shape of release head for 2 J

→ mistake

Reference Figure A.2

5.2 Influence of earth's gravity

When the spring hammer is used in a position differing from the horizontal, the energy, J, actually delivered is modified by ΔE . This variation is positive when the blows are applied downward, and negative when applied upward.

$$\Delta E = 10 \times m \times d \times \sin \alpha$$

where

- m is the mass of the striking element, in kilogrammes;
- d is the travel of the striking element inside the spring hammer, in metres;
- α is the angle of the axis of the striking element with the horizontal.

This variation shall be taken into account when establishing the actual energy delivered.

5.3 Calibration

The spring hammer shall be calibrated. Annex B gives a standardized preferred procedure (see B.2 in particular for 2 J). Other methods of calibration may also be used, provided that evidence is available that they give equivalent accuracy.

6 Test Ehc: Vertical hammer

6.1 Definition

The definition of "height of fall" given in 4.1.2 is applicable.

6.2 Test apparatus

The hammer consists basically of a striking element which falls freely from rest through a vertical height, selected from table 2, on to the specimen surface held in a horizontal plane. The characteristics of the striking element shall comply with table 1. The fall of the striking element shall be along a guideway, for example a tube, with negligible braking. This guideway shall not rest on the specimen and the striking element shall be free of the guideway on striking the specimen. In order to reduce the friction, the length l of the striking element shall not be smaller than its diameter D , and a small gap (for example 1 mm) shall be provided between the striking element and the guideway.

6.3 Height of fall

The height of fall shall be as given in table 2, the equivalent mass stated therein being equal to the actual mass of the striking element.

Annex A
(normative)

Shapes of striking elements

These figures show the characteristics defined in table 1. It is important to note that lengths *l* are calculated for pendulum hammers with arms of negligible mass or for vertical hammers. When this mass cannot be neglected, it shall be reduced so that the equivalent mass meets the requirements of table 1 (see 4.1.3). To comply with the other parameters of table 1, it is necessary to hollow out the end opposite to the striking face for 20 J and 50 J.

Every edge shall be smoothed.

Dimensions in millimetres. Tolerances as per class m of ISO 2768-1, unless otherwise stated.

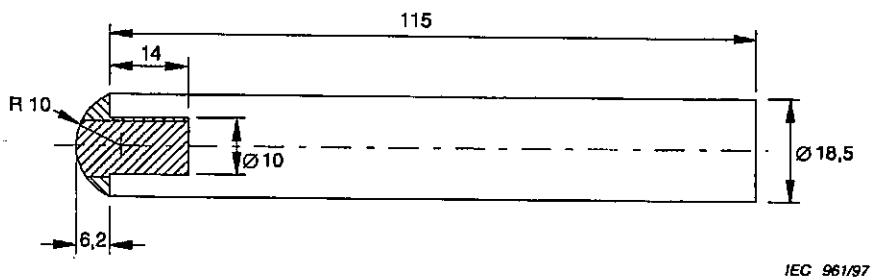

Figure A.1 – Example of a striking element for ≤ 1 J

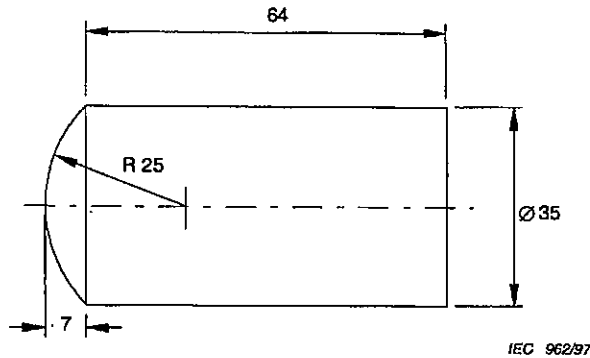

Figure A.2 – Example of a striking element for 2 J

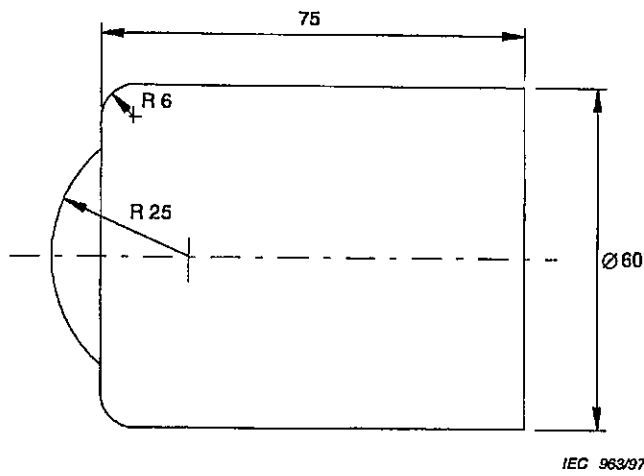

Figure A.3 – Example of a striking element for 5 J

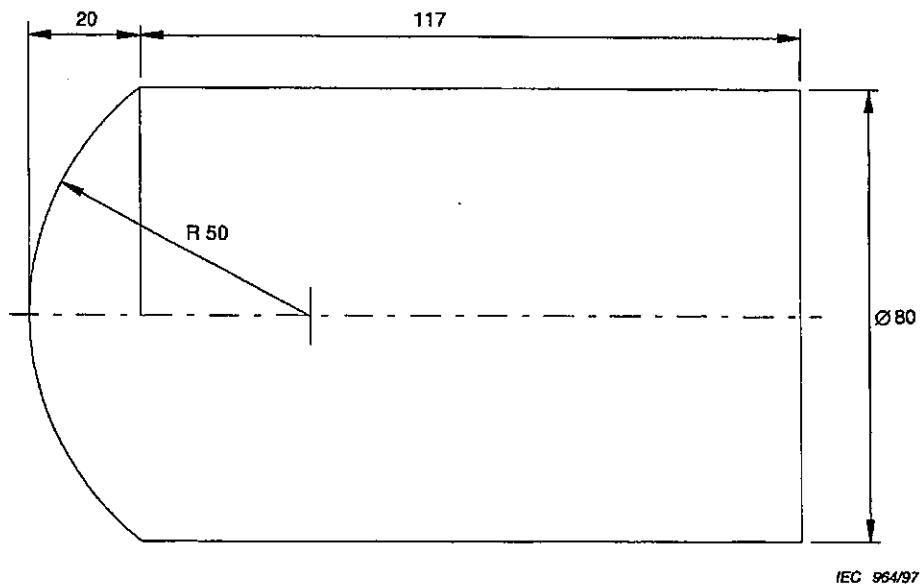

Figure A.4 – Example of a striking element for 10 J

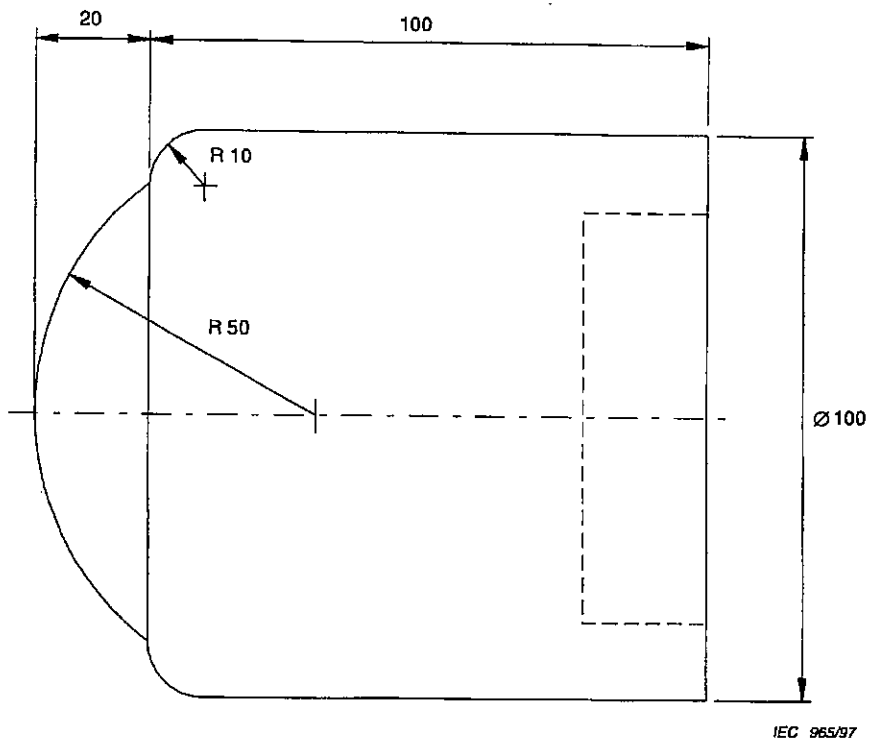

Figure A.5 – Example of a striking element for 20 J

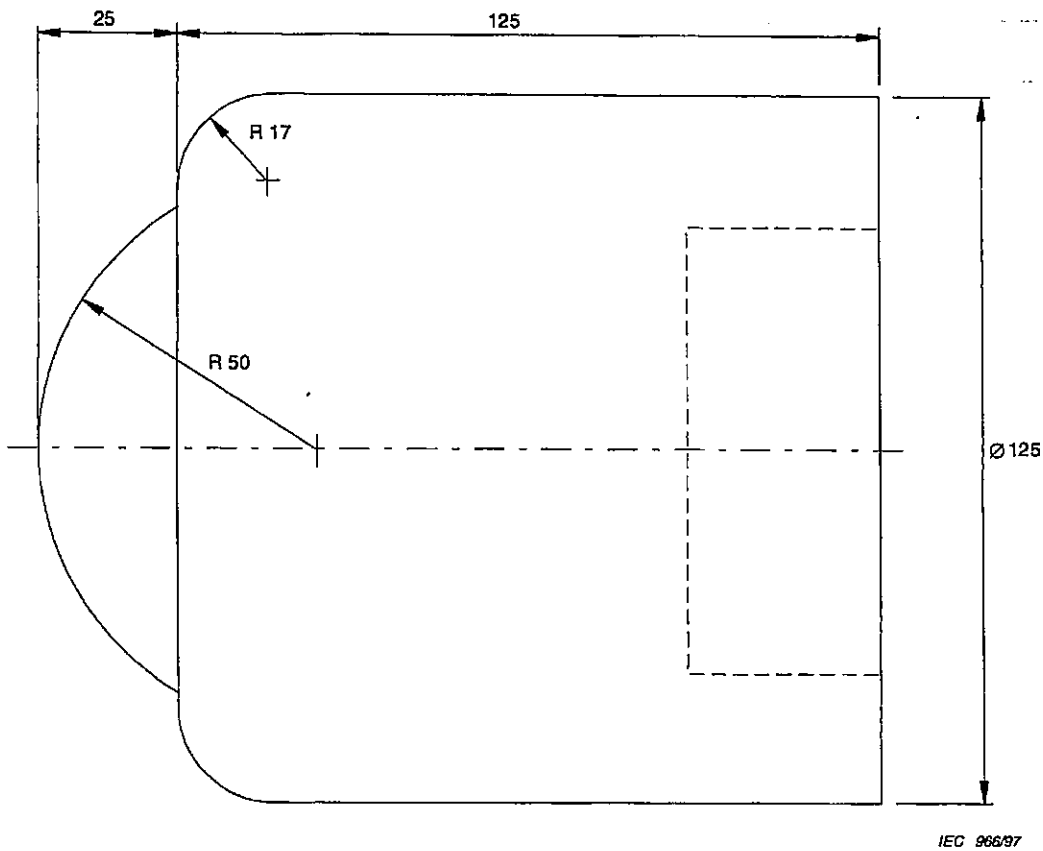

Figure A.6 – Example of a striking element for 50 J

Annex B (normative)

Procedure for the calibration of spring hammers

B.1 Principle of calibration

The principle of this calibration procedure is to compare the energy provided by a spring hammer, which is difficult to measure directly, to the energy of a pendulum, calculated from its mass and height of fall.

B.2 Construction of the calibration device

The assembled calibration device is shown in figure B.1. Apart from the frame, the main parts are a bearing "a", a drag pointer "b", a pendulum "c", a release base "d" and a release device "e".

The main part of the calibration device is the pendulum "c" shown in figure B.2. To the lower end of this pendulum is fixed a steel spring with the details shown in figure B.3. The spring is of spring steel, requiring no special treatment, and is rigidly fixed to the pendulum "c".

Figure B.4 shows some parts on a larger scale

It should be noted that this spring is designed for calibrating spring hammers having characteristics as defined in table 1 for energy values equal to or less than 1 J. For calibrating spring hammers having characteristics as defined for 2 J, the spring of the pendulum of the calibrating device would need to be of a different design.

In order to obtain suitable friction characteristics of the pointer, a piece of thick woven cloth is placed between the metal surfaces of the bearing, the piano wires being bent in such a way that a small force is exerted against the cloth.

Because the release device is removed during the calibration of the calibration device, the release device is fixed to the release base by means of screws.

B.3 Method of calibration of the calibration device

The calibration of the calibration device is effected by using a calibration striking element "g" taken from a spring-hammer, as shown in figure B.5. Before calibration, the release device is removed from the calibrating device.

The calibration striking element is suspended by four linen threads "h" from suspension points situated in a horizontal plane, 2 000 mm above the point of contact between the pendulum and the calibration striking element when the latter is in its rest position. The calibration striking element is allowed to swing against the pendulum and the point of contact under dynamic conditions, point "k", shall be not more than 1 mm below the point of contact in the rest position. The suspension points are then raised over a distance equal to the difference between both contact points.

When the suspension system is adjusted, the axis of the calibration striking element "g" shall be at right angles to the impact surface of the pendulum "c" and the calibration striking element shall be horizontal at the moment of impact.

When the calibration striking element is in its rest position, the calibration device is placed so that point "k" is positioned exactly at the head of the calibration striking element.

To obtain reliable results, the calibration device is rigidly fixed to a massive support, for example to a structural part of a building.

The height of fall is measured at the centre of gravity of the calibration striking element and the measurement can be facilitated by using a liquid level device consisting of two glass tubes "j", which are interconnected by means of a flexible hose. One of the glass tubes is fixed and provided with a scale "l".

The calibration striking element may be held in its upper position by means of a thin thread "m" which, when ruptured, causes the release of the calibration striking element.

For scaling the calibration device, a circle is drawn on the scale plate, the centre of this circle coinciding with the bearing of the pendulum and its radius being such that the circle extends to the drag pointer. On this circle, the zero point 0 J shown in figure B.6 is marked at the point indicated by the drag pointer when the latter is brought into contact with the pendulum in the rest position.

The calibration is made with an impact energy of 1 J, which is achieved with a height of fall of $408 \text{ mm} \pm 1 \text{ mm}$, with a calibration striking element of 250 g.

The point on the scale plate corresponding to 1 J is obtained by allowing the suspended calibration striking element to swing against the point "k" on the spring of the pendulum. After hitting the pendulum, the calibration striking element shall not move. The operation is repeated at least 10 times and the 1 J point is the average of the indications of the drag pointer.

The other points of the scale are then determined as follows:

- a) a straight line is drawn through the centre of the circle and the 0 J point;
- b) the orthogonal projection of the 1 J point on this line is indicated by P;
- c) the distance between the points 0 J and P is divided into 10 equal parts;
- d) through each dividing point, a line is drawn perpendicular to the line 0 J-P;
- e) the intersections between these lines and the circle correspond to values of impact energy equal to 0,1 J; 0,2 J; up to 0,9 J.

The same principle can be used for extending the scale beyond the 1 J point. The division of the scale plate "f" is shown in figure B.6.

B.4 Use of the calibration device

The spring hammer to be calibrated is put in the release base and is then operated three times by means of the release device; it shall not be released manually.

For each operation, the striking element of the spring hammer to be calibrated is turned in a different position. The average value of the three readings on the calibration device is taken to be the actual value of the impact energy of the specimen.

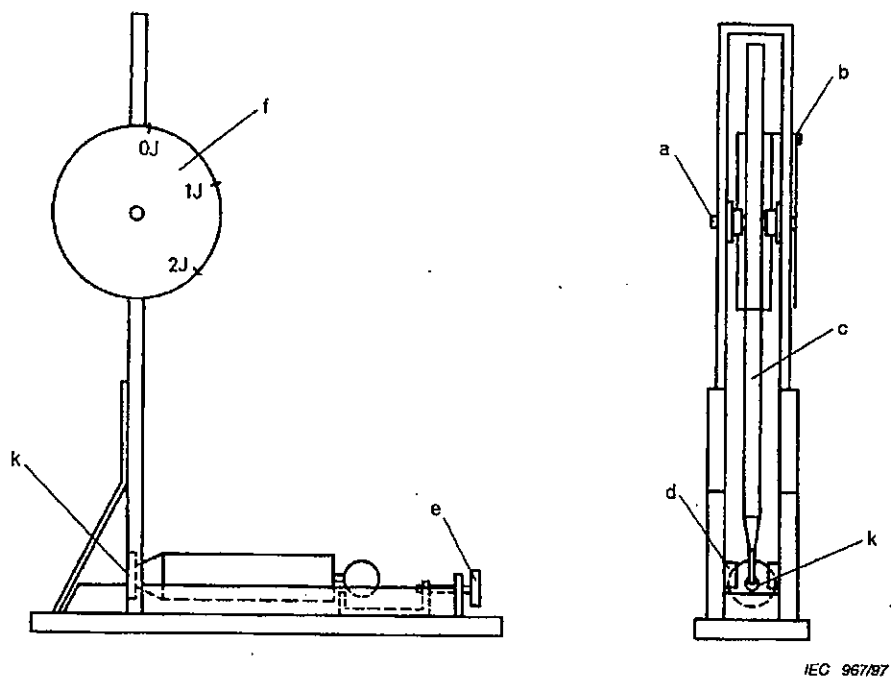

- a = bearing
- b = drag pointer
- c = pendulum
- d = release base
- e = release device
- f = scale plate
- k = point where blows are applied, i.e. impact point

Figure B.1 – Calibration device

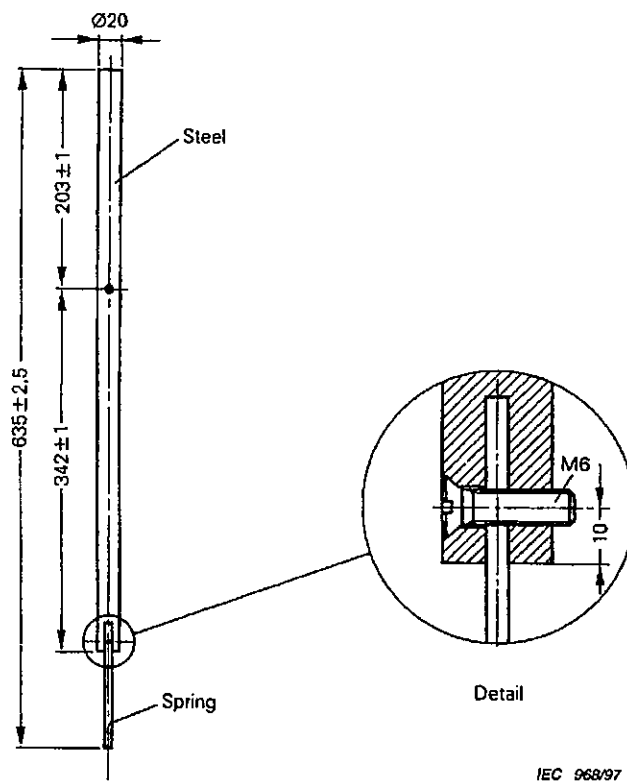

Figure B.2 – Pendulum "c"

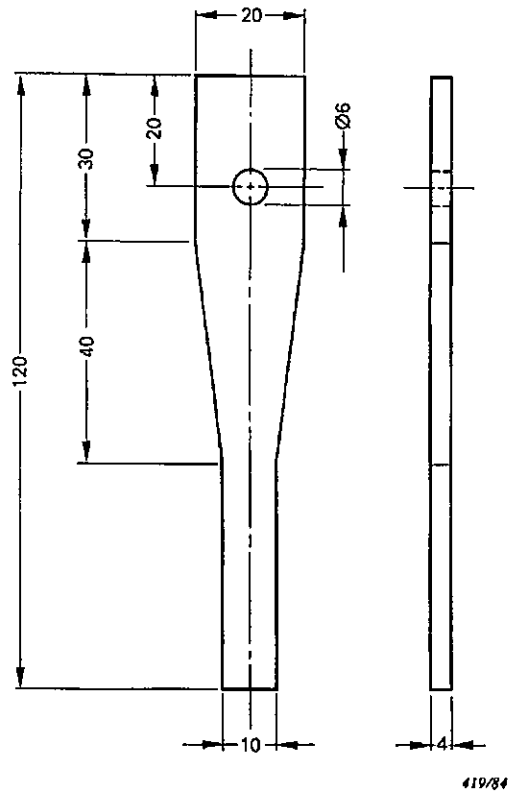
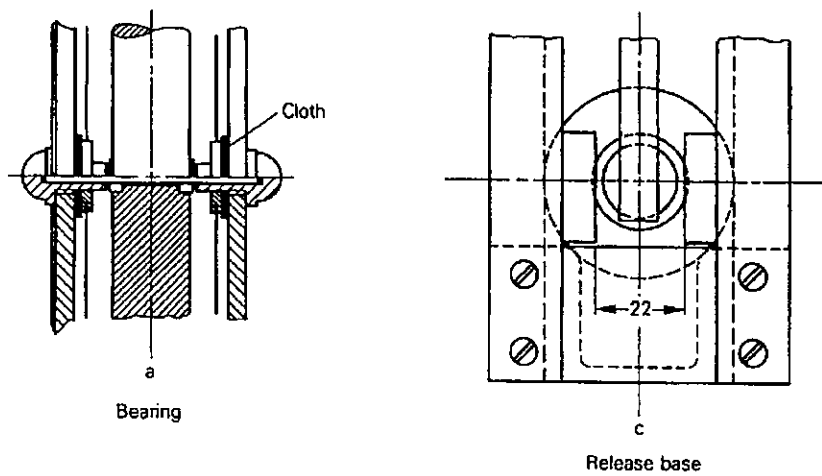

Figure B.3 – Steel spring of pendulum "c"



IEC 969/97

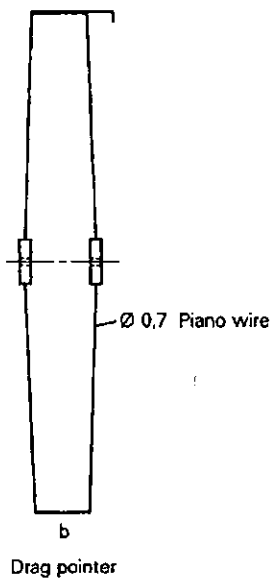
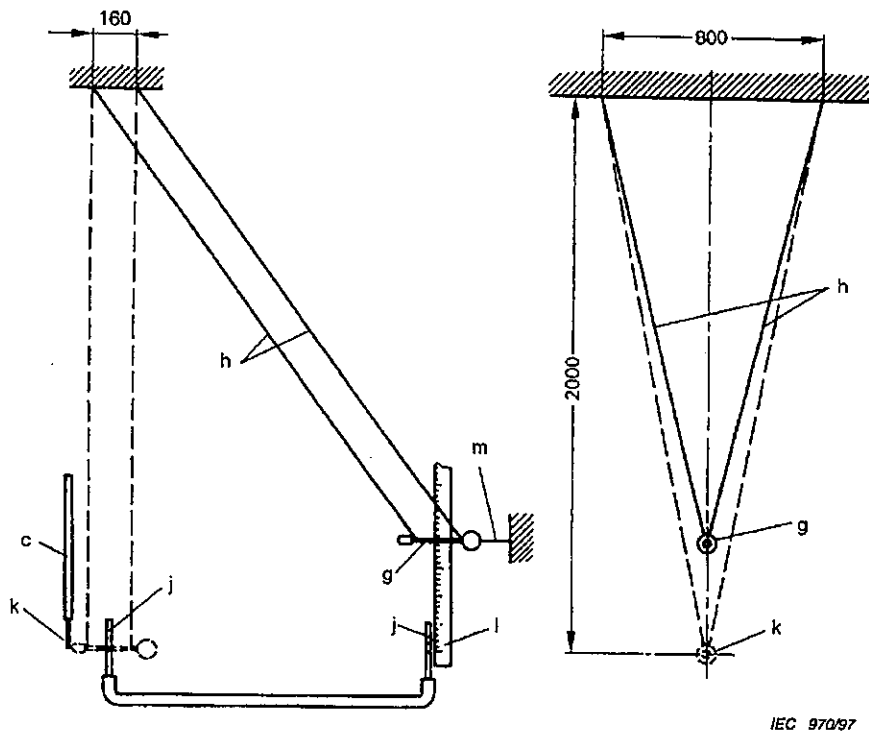

Figure B.4 – Details of calibration device



IEC 970/97

- c = pendulum of figure B.1
- g = calibration striking element
- h = linen threads
- j = glass tubes
- k = impact point
- l = scale
- m = thin thread

For clarity only the pendulum "c" of the calibration device is shown in this figure.

Figure B.5 – Arrangement for the calibration of the calibration device

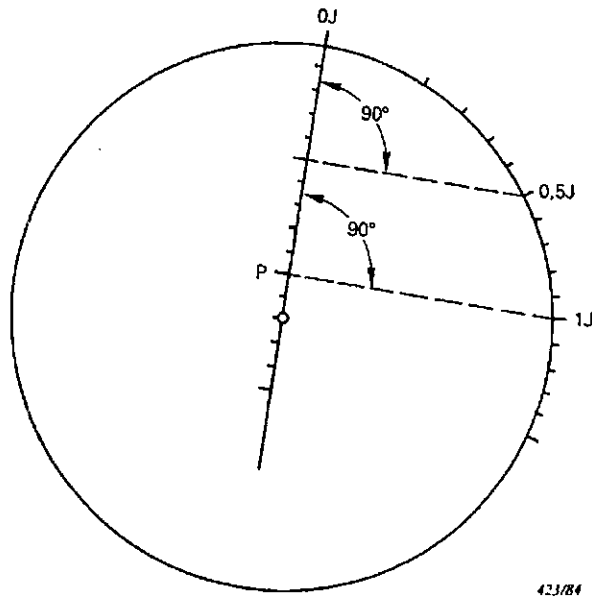

Figure B.6 – Division of scale plate "f"

Annex C
(informative)
Guidance

C.1 When is an impact test appropriate ?

An impact test is appropriate for equipment likely to be used in areas with non-restricted access and where impacts are likely to occur. For equipment destined for areas with restricted access, an impact test may be appropriate but is likely to be of a lower severity.

It is particularly applicable when the equipment is of a brittle nature.

C.2 Choice of the test apparatus

This part of IEC 60068 provides for three methods of test which, as far as is practicable, are intended to give similar results. To obtain repeatable and reproducible results, this test is more dependent on the details of the test apparatus than is usual in IEC 60068 standards.

The choice of the test apparatus depends on the orientation of the surface to be tested and on the energy level. Not all methods can be used in every case. It is self-evident that a pendulum hammer can only be used on vertical surfaces without overhangings. Similarly the vertical hammer can normally only be used on accessible horizontal surfaces. When the specimen cannot be moved or turned, for any reason, the choice is limited. The advantage of the spring hammer is that it can be used in any position, provided there is enough room to apply it correctly, and that the specified impact energy does not exceed 2 J. For higher energy levels, a spring hammer would be too difficult to handle, and could even be hazardous for the operator.

C.3 Choice of the energy level

The energy of impacts depends on the mass of the striking object and its speed, which may be generated by its fall. The following table C.1 gives theoretical energy levels which approximate to values given in this part of IEC 60068.

Table C.1 - Energy levels in joules

Height of fall m	Speed m/s	Mass of striking object kg					
		0,1	0,2	0,5	1	2	5
0,1	1,4	0,1	0,2	0,5	1	2	5
0,2	2	0,2	0,4	1	2	4	10
0,5	3,1	0,5	1	2,5	5	10	25
1	4,4	1	2	5	10	20	50

The values of table C.1 correspond to blows perpendicular to the specimen surface.

Much higher energies can be encountered in particular situations such as vandalism or in a car accident. In these cases, consideration should be given to the use of additional protection such as barriers or walls.

C.4 Information for testing

The temperature of the specimen may influence the results of the tests and the relevant specification should take this into account when applicable.

Impact tests can be specified in sequence with other tests, but attention is drawn to the fact that some standardized tests are required to be performed on new specimens, which excludes previous hammer tests.

The main performance criteria should be derived from how the operational and survival characteristics of the specimen are influenced by mechanical impacts.

The other important aspect is safety, which can be the prime consideration in certain circumstances.

Annex D (informative)

Example of pendulum hammer test apparatus

Figure D.1 shows an example of a pendulum hammer test apparatus for energies not exceeding 1 J. The striking element complies with 4.2.1 and figure D.2. The arm is a steel tube with an external diameter of 9 mm (nominal), and a wall thickness of 0,5 mm (nominal).

The specimens are mounted on a sheet of plywood 8 mm thick and 175 mm square, preferably according to ISO 1098*, secured at its top and bottom edges to a rigid bracket, which is part of the mounting fixture, as shown as an example in figure D.3. The mounting fixture has a mass of $10 \text{ kg} \pm 1 \text{ kg}$ and is mounted on a rigid frame by means of pivots. The frame is itself fixed to a solid wall.

The design of the mounting is such that

- a) the specimen can be so placed that the point of impact lies in the vertical plane through the axis of the pendulum pivot;
- b) the specimen can be moved horizontally and turned about an axis perpendicular to the surface of the plywood;
- c) the plywood can be turned about a vertical axis.

The specimens are mounted on the plywood as in normal service. Where it is not possible to mount the specimen directly on the plywood, a suitable adapter would need to be prescribed by the relevant specification. An example of an adapter for flush-type switches is shown in figure D.4, and an example of an adapter for lamp holders is shown in figure D.5.

* ISO 1098: 1975, *Veneer plywood for general use – General requirements.*

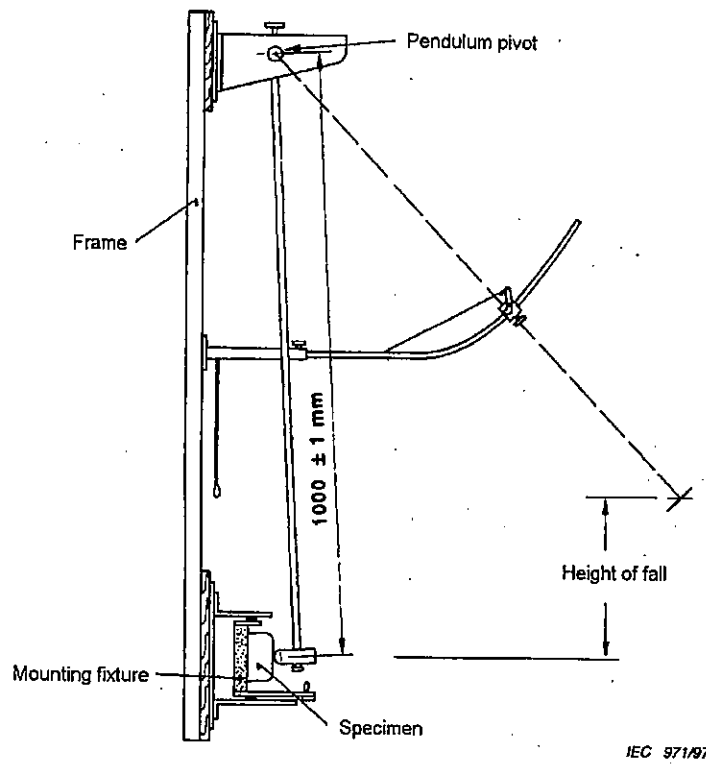
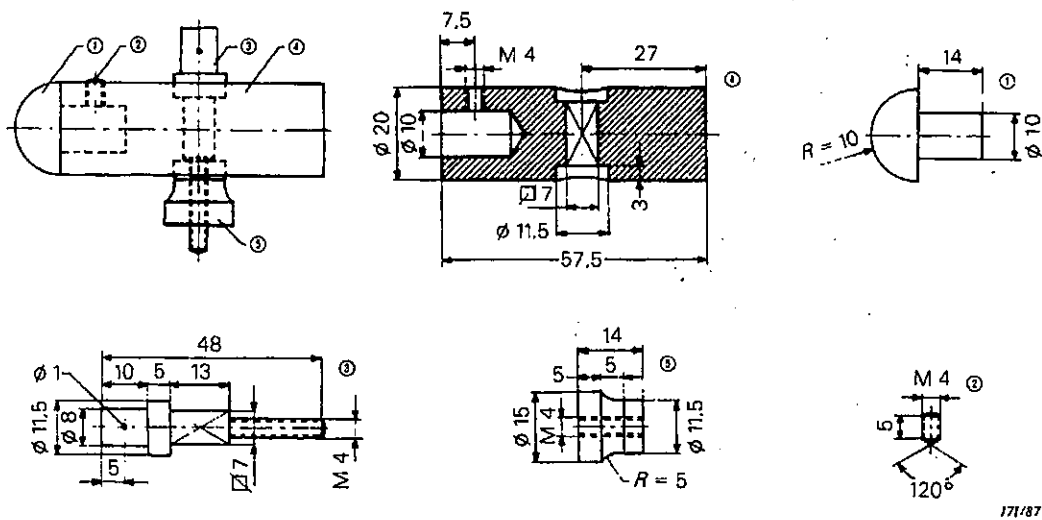
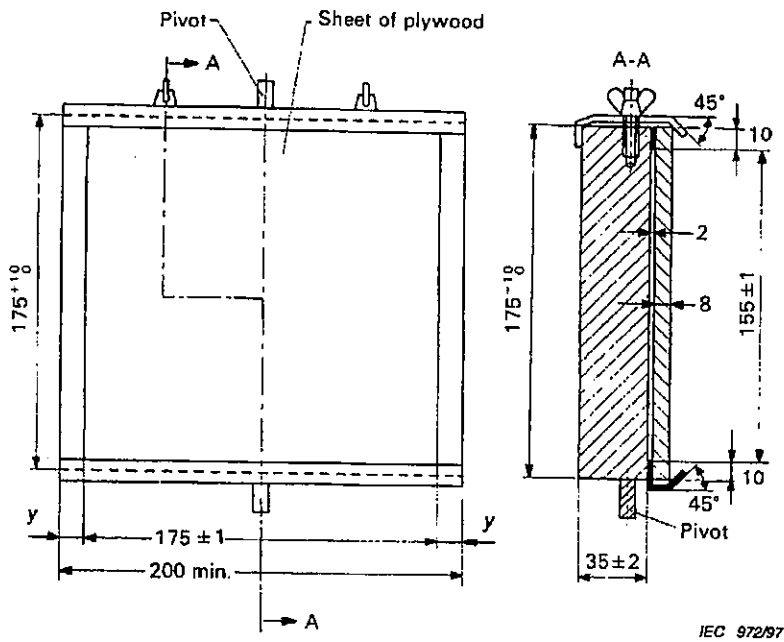

Figure D.1 - Test apparatus



Note - See table 1
Dimensions in millimetres

Figure D.2 - Striking element of the pendulum hammer for energies ≤ 1 J



Dimensions in millimetres

Figure D.3 – Mounting fixture

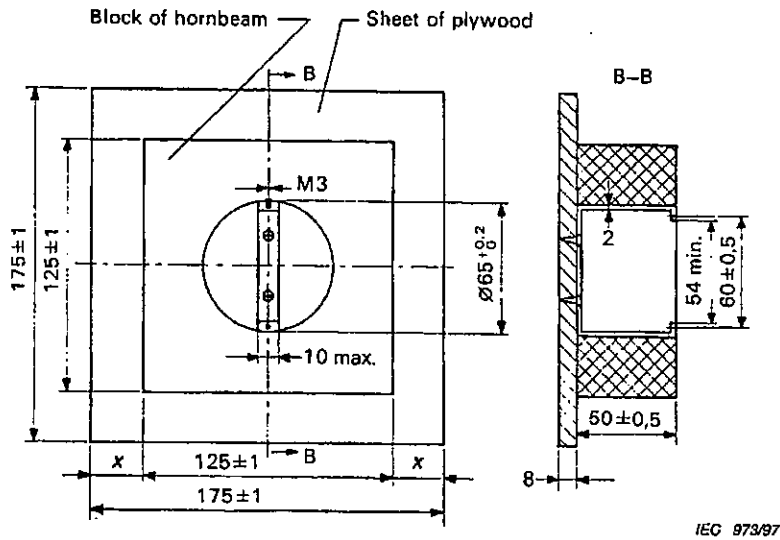

Dimensions in millimetres

Figure D.4 – Adapter for flush-type switches

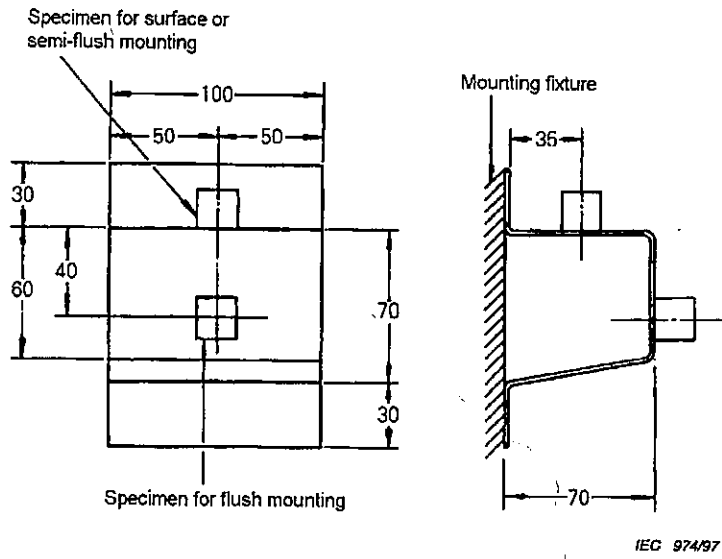

Dimensions in millimetres

Figure D.5 - Adapter for lamp holders

Annex E
(informative)

Example of spring hammer test apparatus

Figure E.1 shows an example of a spring hammer test apparatus complying with clause 5, for energies not exceeding 1 J. The mass of the body assembly is 1250 g ± 10 g. The hammer head is fixed to the hammer shaft in such a way that the distance from its tip to the plane of impact (the plane of the cone truncation), when the striking element is on the point of release, has approximately the value shown for the spring compression in table E.1.

Table E.1 – Kinetic energy of striking element

Kinetic energy (<i>E</i>) just before impact J	Approximate spring compression with spring constant of $2,75 \times 10^3$ N/m mm
0,14 ± 0,014	10
0,20 ± 0,02	13
0,35 ± 0,03	17
0,50 ± 0,04	20
0,70 ± 0,05	24
1,00 ± 0,05	28

NOTE – The approximate value of the kinetic energy in joules, just before the impact, can be calculated from the following formula:

$$E = 0,5 FC \times 10^{-3}$$

where

- F* is the force exerted by the hammer spring, when fully compressed, in newtons;
- C* is the compression of the hammer spring, in millimetres

The energy stated above is achieved in the horizontal position.

The cone has a mass of approximately 60 g and the cone spring is such that it exerts a force of approximately 5 N when the release jaws are on the point of releasing the striking element. The release mechanism springs are adjusted so that they exert just sufficient pressure to keep the release jaws in the engaged position.

The apparatus is cocked by pulling the cocking knob back until the release jaws engage with the groove in the hammer shaft. The release cone of the test apparatus is pushed against the prescribed position(s) on the specimen perpendicular to the surface of the specimen. The pressure is slowly increased so that the cone moves back relative to the body of the apparatus until it is in contact with the release bars, which then move to operate the release mechanism and allow the hammer to strike the specimen.

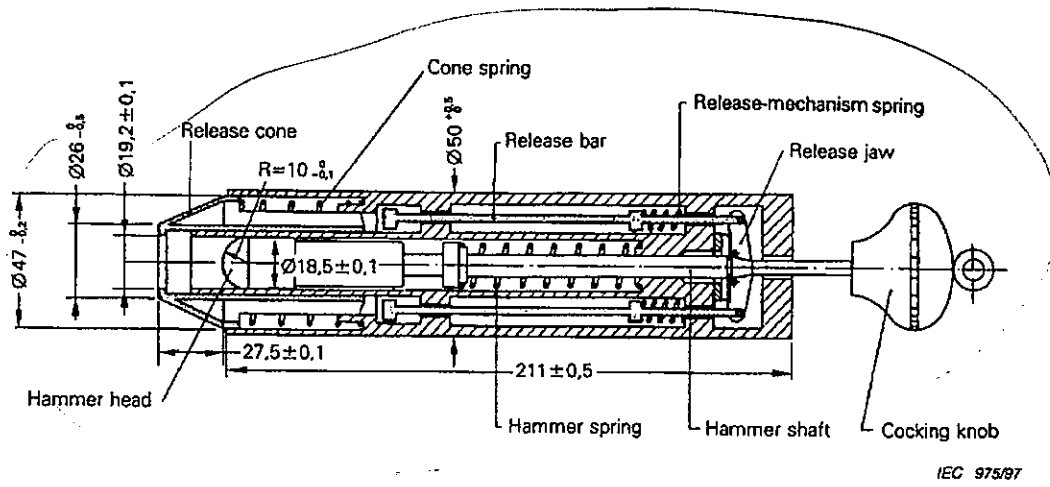

Figure E.1 – Spring hammer test apparatus

1. No. of IEC standard:

2. Tell us why you have the standard. (check as many as apply). I am:
 the buyer
 the user
 a librarian
 a researcher
 an engineer
 a safety expert
 involved in testing
 with a government agency
 in industry
 other.....

3. This standard was purchased from?

4. This standard will be used (check as many as apply):
 for reference
 in a standards library
 to develop a new product
 to write specifications
 to use in a tender
 for educational purposes
 for a lawsuit
 for quality assessment
 for certification
 for general information
 for design purposes
 for testing
 other.....

5. This standard will be used in conjunction with (check as many as apply):
 IEC
 ISO
 corporate
 other (published by.....)
 other (published by.....)
 other (published by.....)

6. This standard meets my needs (check one)
 not at all
 almost
 fairly well
 exactly

7. Please rate the standard in the following areas as (1) bad, (2) below average, (3) average, (4) above average, (5) exceptional, (0) not applicable:
 clearly written
 logically arranged
 information given by tables
 illustrations
 technical information

8. I would like to know how I can legally reproduce this standard for:
 internal use
 sales information
 product demonstration
 other.....

9. In what medium of standard does your organization maintain most of its standards (check one):
 paper
 microfilm/microfiche
 mag tapes
 CD-ROM
 floppy disk
 on line

9A. If your organization currently maintains part or all of its standards collection in electronic media, please indicate the format(s):
 raster image
 full text

10. In what medium does your organization intend to maintain its standards collection in the future (check all that apply):
 paper
 microfilm/microfiche
 mag tape
 CD-ROM
 floppy disk
 on line

10A. For electronic media which format will be chosen (check one)
 raster image
 full text

11. My organization is in the following sector (e.g. engineering, manufacturing)

12. Does your organization have a standards library:
 yes
 no

13. If you said yes to 12 then how many volumes:

14. Which standards organizations published the standards in your library (e.g. ISO, DIN, ANSI, BSI, etc.):

15. My organization supports the standards-making process (check as many as apply):
 buying standards
 using standards
 membership in standards organization
 serving on standards development committee
 other.....

16. My organization uses (check one)
 French text only
 English text only
 Both English/French text

17. Other comments:

18. Please give us information about you and your company
 name:
 job title:.....
 company:
 address:.....

.....
 No. employees at your location:.....
 turnover/sales:.....

1. Numéro de la Norme CEI:
.....

2. Pourquoi possédez-vous cette norme? (plusieurs réponses possibles). Je suis:

- l'acheteur
- l'utilisateur
- bibliothécaire
- chercheur
- ingénieur
- expert en sécurité
- chargé d'effectuer des essais
- fonctionnaire d'Etat
- dans l'industrie
- autres

3. Où avez-vous acheté cette norme?
.....

4. Comment cette norme sera-t-elle utilisée? (plusieurs réponses possibles)

- comme référence
- dans une bibliothèque de normes
- pour développer un produit nouveau
- pour rédiger des spécifications
- pour utilisation dans une soumission
- à des fins éducatives
- pour un procès
- pour une évaluation de la qualité
- pour la certification
- à titre d'information générale
- pour une étude de conception
- pour effectuer des essais
- autres

5. Cette norme est-elle appelée à être utilisée conjointement avec d'autres normes? Lesquelles? (plusieurs réponses possibles):

- CEI
- ISO
- internes à votre société
- autre (publiée par).....)
- autre (publiée par).....)
- autre (publiée par).....)

6. Cette norme répond-elle à vos besoins?

- pas du tout
- à peu près
- assez bien
- parfaitement

7. Nous vous demandons maintenant de donner une note à chacun des critères ci-dessous (1, mauvais; 2, en-dessous de la moyenne; 3, moyen; 4, au-dessus de la moyenne; 5, exceptionnel; 0, sans objet)

- clarté de la rédaction
- logique de la disposition
- tableaux informatifs
- illustrations
- informations techniques

8. J'aimerais savoir comment je peux reproduire légalement cette norme pour:

- usage interne
- des renseignements commerciaux
- des démonstrations de produit
- autres

9. Quel support votre société utilise-t-elle pour garder la plupart de ses normes?

- papier
- microfilm/microfiche
- bandes magnétiques
- CD-ROM
- disquettes
- abonnement à un serveur électronique

9A. Si votre société conserve en totalité ou en partie sa collection de normes sous forme électronique, indiquer le ou les formats:

- format tramé (ou image balayée ligne par ligne)
- texte intégral

10. Sur quels supports votre société prévoit-elle de conserver sa collection de normes à l'avenir (plusieurs réponses possibles):

- papier
- microfilm/microfiche
- bandes magnétiques
- CD-ROM
- disquettes
- abonnement à un serveur électronique

10A. Quel format serait retenu pour un moyen électronique? (une seule réponse)

- format tramé
- texte intégral

11. A quel secteur d'activité appartient votre société? (par ex. ingénierie, fabrication)
.....

12. Votre société possède-t-elle une bibliothèque de normes?

- Oui
- Non

13. En combien de volumes dans le cas affirmatif?
.....

14. Quelles organisations de normalisation ont publié les normes de cette bibliothèque (ISO, DIN, ANSI, BSI, etc.):
.....

15. Ma société apporte sa contribution à l'élaboration des normes par les moyens suivants (plusieurs réponses possibles):

- en achetant des normes
- en utilisant des normes
- en qualité de membre d'organisations de normalisation
- en qualité de membre de comités de normalisation
- autres

16. Ma société utilise (une seule réponse)

- des normes en français seulement
- des normes en anglais seulement
- des normes bilingues anglais/français

17. Autres observations
.....
.....
.....
.....
.....
.....

18. Pourriez-vous nous donner quelques informations sur vous-mêmes et votre société?

nom

fonction

nom de la société

adresse

.....

.....

.....

nombre d'employés.....

chiffre d'affaires:.....

**Publications de la CEI préparées
par le Comité d'Etudes n° 104 (suite)**

- 60068-2-40 (1976) Essai Z/AM: Essais combinés froid/basse pression atmosphérique. Modification no 1 (1983).
- 60068-2-41 (1976) Essai Z/BM: Essais combinés chaleur sèche/basse pression atmosphérique. Modification no 1 (1983).
- 60068-2-42 (1982) Essai Kc: Essai à l'anhydride sulfureux pour contacts et connexions.
- 60068-2-43 (1976) Essai Kd: Essai à l'hydrogène sulfuré pour contacts et connexions.
- 60068-2-44 (1995) Guide pour l'essai T: Soudure.
- 60068-2-45 (1980) Essai XA et guide: Immersion dans les solvants de nettoyage. Amendement I (1993).
- 60068-2-46 (1982) Guide pour essai Kd: Essai à l'hydrogène sulfuré pour contacts et connexions.
- 60068-2-47 (1982) Fixation de composants, matériels et autres articles pour essais dynamiques tels que chocs (Ea), secousses (Eb), vibrations (Fc et Fd) et accélération constante (Ga) et guide.
- 60068-2-48 (1982) Guide sur l'utilisation des essais de la Publication 68 de la CEI pour simuler les effets du stockage.
- 60068-2-49 (1983) Guide pour essai Kc: Essai à l'anhydride sulfureux pour contacts et connexions.
- 60068-2-50 (1983) Essais Z/AFc: Essais combinés froid/vibrations (sinusoïdales) pour spécimens dissipant et ne dissipant pas d'énergie.
- 60068-2-51 (1983) Essais Z/BFc: Essais combinés chaleur sèche/vibrations (sinusoïdales) pour spécimens dissipant et ne dissipant pas d'énergie.
- 60068-2-52 (1996) Essai Kb: Brouillard salin, essai cyclique (solution de chlorure de sodium).
- 60068-2-53 (1984) Guide pour les essais Z/AFc et Z/BFc: Essais combinés température (froid et chaleur sèche) et vibrations (sinusoïdales).
- 60068-2-54 (1985) Essai Ta: Soudure. Essai de soudabilité par la méthode de la balance de mouillage.
- 60068-2-55 (1987) Essai Ee et guide: Rebondissement.
- 60068-2-56 (1988) Essai Cb: Chaleur humide, essai continu, recommandé principalement pour les équipements.
- 60068-2-57 (1989) Essai Ff: Vibrations - Méthode par accélérographes.
- 60068-2-58 (1989) Essai Td: Soudabilité, résistance de la métallisation à la dissolution et résistance à la chaleur de soudage des composants pour montage en surface (CMS).
- 60068-2-59 (1990) Essai Fe: Vibrations - Méthode par sinusoïdes modulées.
- 60068-2-60 (1995) Essai Ke: Essai de corrosion dans un flux de mélange de gaz.
- 60068-2-61 (1991) Essai Z/ABDM: Séquence climatique.
- 60068-2-62 (1991) Essai Ef: Impacts, marteau pendulaire. Amendement I (1993).
- 60068-2-63 (1991) Essai Eg: Impacts, marteau à ressort.
- 60068-2-64 (1993) Essai Fh: Vibrations aléatoires à large bande (asservissement numérique) et guide.
- 60068-2-65 (1993) Essai Fg: Vibrations, induites acoustiquement.
- 60068-2-66 (1994) Essai Cx: Essai continu de chaleur humide (vapeur pressurisée non saturée).
- 60068-2-67 (1995) Essai Cy: Essai continu de chaleur humide, essai accéléré applicable en premier lieu aux composants.
- 60068-2-68 (1994) Essai L: Poussière et sable.

(suite)

**IEC publications prepared
by Technical Committee No. 104 (continued)**

- 60068-2-40 (1976) Test Z/AM: Combined cold/low air pressure tests. Amendment No. 1 (1983).
- 60068-2-41 (1976) Test Z/BM: Combined dry heat/low air pressure tests. Amendment No. 1 (1983).
- 60068-2-42 (1982) Test Kc: Sulphur dioxide test for contacts and connections.
- 60068-2-43 (1976) Test Kd: Hydrogen sulphide test for contacts and connections.
- 60068-2-44 (1995) Guidance on Test T: Soldering.
- 60068-2-45 (1980) Test XA and guidance: Immersion in cleaning solvents. Amendment 1 (1993).
- 60068-2-46 (1982) Guidance to Test Kd: Hydrogen sulphide test for contacts and connections.
- 60068-2-47 (1982) Mounting of components, equipment and other articles for dynamic tests including shock (Ea), bump (Eb), vibration (Fc and Fd) and steady-state acceleration (Ga) and guidance.
- 60068-2-48 (1982) Guidance on the application of the tests of IEC Publication 68 to simulate the effects of storage.
- 60068-2-49 (1983) Guidance to Test Kc: Sulphur dioxide test for contacts and connections.
- 60068-2-50 (1983) Tests Z/AFc: Combined cold/vibration (sinusoidal) tests for both heat-dissipating and non-heat-dissipating specimens.
- 60068-2-51 (1983) Tests Z/BFc: Combined dry heat/vibration (sinusoidal) tests for both heat-dissipating and non-heat-dissipating specimens.
- 60068-2-52 (1996) Test Kb: Salt mist, cyclic (sodium chloride solution).
- 60068-2-53 (1984) Guidance to tests Z/AFc and Z/BFc: Combined temperature (cold and dry heat) and vibration (sinusoidal) tests.
- 60068-2-54 (1985) Test Ta: Soldering. Solderability testing by the wetting balance method.
- 60068-2-55 (1987) Test Ee and guidance: Bounce.
- 60068-2-56 (1988) Test Cb: Damp heat, steady state, primarily for equipment.
- 60068-2-57 (1989) Test Ff: Vibration - Time-history method.
- 60068-2-58 (1989) Test Td: Solderability, resistance to dissolution of metallization and to soldering heat of Surface Mounting Devices (SMD).
- 60068-2-59 (1990) Test Fe: Vibration - Sine-beat method.
- 60068-2-60 (1995) Test Ke: Flowing mixed gas corrosion test.
- 60068-2-61 (1991) Test Z/ABDM: Climatic sequence.
- 60068-2-62 (1991) Test Ef: Impact, pendulum hammer. Amendment 1 (1993).
- 60068-2-63 (1991) Test EG: Impact, spring hammer.
- 60068-2-64 (1993) Test Fh: Vibration, broad-band random (digital control) and guidance.
- 60068-2-65 (1993) Test Fg: Vibration, acoustically induced.
- 60068-2-66 (1994) Test Cx: Damp heat, steady state (unsaturated pressurized vapour).
- 60068-2-67 (1995) Test Cy: Damp heat, steady state, accelerated test primarily intended for components.
- 60068-2-68 (1994) Test L: Dust and sand.

(continued)

ISBN 2-8318-3921-1



9 782831 839219

ICS 19.040

Typeset and printed by the IEC Central Office
GENEVA, SWITZERLAND